

AVF 234S: SUT valve actuator with spring return

How energy efficiency is improved

Automatic adaptation to valve, precision activation and high energy efficiency with minimal operating noise

Features

- Activation of 2-way and 3-way valves of the VQD/BQD, VQE/BQE, VUG/BUG, VUP, VUS/BUS and V6R/B6R series
- For controllers with switching (2- and 3-point) and continuous (0...10 V, 4...20 mA) output
- Spring return moves to end position in the event of a power failure/interruption or when a limit controller is activated
- Stepping motor with SAUTER Universal Technology (SUT) electronic control unit and electronic, force-dependent cut-off
- Simple assembly with valve; spindle is automatically connected after control voltage is applied (patented system)
- Automatic detection of applied control signal (constant or switched); indicated by two LEDs
- Coding switches for selecting characteristic and running time
- Type of characteristic (linear/quadratic/equal-percentage) can be set on the actuator
- Automatic adaptation to the stroke of the valve (min. valve stroke 8 mm, max. valve stroke 49 mm). The measured stroke is saved and is not lost even in the event of a power failure
- Direction of operation can be selected via screw terminals when making the electrical connection
- Crank handle for external manual adjustment with motor cut-off and as trigger for a re-initialisation
- Numerous adapters enable the unit to be fitted onto non-SAUTER valves
- Power supply 230 V with module or direct connection for 24 VAC or 24 VDC; continuous activation also admissible with 230 V
- Maintenance-free gear unit made of sintered steel; gearbox base-plate made of steel
- Spring pack and mounting column made of stainless steel; mounting bracket made of cast light alloy for valve fitting
- Electrical connections (max. 2.5 mm²) with screw terminals
- Three pre-scored cable inlets for M20 × 1.5 (2×) and M16 × 1.5
- Fitting vertically upright to horizontal, not suspended

Technical data

Power supply

Power supply 24 VAC	±20%, 50...60 Hz
Power supply 24 VDC	±15%
Power supply 230 VAC	±15%, 50...60 Hz (with accessories)
Power consumption ¹⁾	24 VAC/24 VDC 10 W, 20 VA 230 VAC (with accessories) 13 W/28 VA

Parameters

Running time of motor	2/4/6 s/mm
Running time of spring ²⁾	15...30 s
Actuating power	2000 N
Response time for 3-point	200 ms
Number of spring returns	> 40 000

Positioner

Control signal 1	0...10 V, R _i = 100 kΩ
Control signal 2	4...20 mA, R _i = 50 Ω
Positional feedback 0...10 V	0...10 V, load > 10 kΩ
Starting point U ₀	0 V or 10 V
Control span ΔU	10 V
Switching range X _{sh}	300 mV

¹⁾ Choose transformers for this value, otherwise malfunctions may occur

²⁾ Return time equates to a stroke of 14...40 mm and does not depend on the set running time



AVF234SF132



AVF234SF132



AVF234SF232

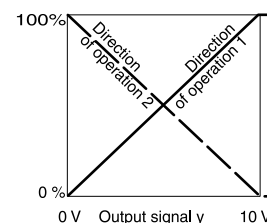

ValveDim app



Ambient conditions		
Ambient temperature		-10...55 °C
Ambient humidity		< 95% rh, no condensation
Media temperature ³⁾		Max. 130 °C (180 °C or 240 °C with accessories)

Construction		
Weight		5.6 kg
Housing		Two-part, yellow
Housing material		Flame-retardant plastic

Standards, directives		
Type of protection		IP66 (EN 60529)
Protection class		III (IEC 60730)
Over-voltage categories		III
Degree of contamination		III
CE/UKCA conformity ⁴⁾	LV-D 2014/35/EU (CE)	EN 60730-1, EN 60730-2-14
	EESR-2016 (UKCA)	EN 60730-1, EN 60730-2-14
	EMC-D 2014/30/EU (CE)	EN 61000-6-2, EN 61000-6-4
	EMC-2016 (UKCA) ⁵⁾	EN 61000-6-2, EN 61000-6-4
	RoHS-D 2011/65/EU & 2015/863/EU (CE)	EN IEC 63000:2018
	RoHS-2012 (UKCA)	EN IEC 63000:2018

Overview of types					
Type	Voltage	Stroke	Running time	Power consumption	Direction of operation of spring
AVF234SF132	24 VAC/DC	14...40 mm	2/4/6 s/mm	10 W, 20 VA	Spindle retracted
AVF234SF132-5	24 VAC/DC	14 mm	2/4/6 s/mm	10 W, 20 VA	Spindle retracted
AVF234SF232	24 VAC/DC	0...40 mm	2/4/6 s/mm	10 W, 20 VA	Spindle extended

☛ AVF234SF132: Valve normally closed (NC) with: VQD/BQD, VQE/BQE, VUG/BUG, BUS; valve normally open (NO) with: VUS, VUP

☛ AVF234SF132-5: Valve normally closed (NC) with: V6R, B6R

☛ AVF234SF232: Valve normally open (NO) with: VQD/BQD, VQE/BQE, VUG/BUG, BUS; valve normally closed (NC) with: VUS, VUP

Accessories	
Type	Description
0313529001	Split-range unit for setting sequences

Modules can be added for 2-point/3-point and continuous activation; additional power 2 VA

Type	Description
0372332001	230 V ±15%, supply voltage
0372332002	100 V ±15%, supply voltage

Auxiliary change-over contacts (2 each) 12...250 VAC

Type	Description
0372333001	Auxiliary change-over contacts (sets of 2), 12...250 VAC, infinitely variable, min. 100 mA and 12 V permissible load 6(2) A
0372333002	Auxiliary change-over contacts (sets of 2), 12...250 VAC, gold-plated contacts, from 1 mA, to max. 30 V, wider range 3(1) A

Potentiometers

Type	Description
0372334001	Potentiometer, 2000 Ω, 1 W, 24 V
0372334006	Potentiometer, 1000 Ω, 1 W, 24 V

³⁾ An adapter is needed for higher temperatures (180 °C or 240 °C) (see accessories)

⁴⁾ Explanation of abbreviations in "Additional technical data" section

⁵⁾ EN 61000-6-2: HF immunity, limitation of feedback signal between 80 MHz and 1000 MHz criterion B, otherwise criterion A

Adapters for high temperatures

Type	Description
0372336180	Adapter (required when temperature of the medium is 130...150 °C)
0372336240	Adapter (required when temperature of the medium is 180...200 °C)

Mounting set for AVF234SF*32 onto SAUTER valves (no adapter needed for 0372338 002)

Type	Description
0372338001	V/B6 to DN 50, V/BXD, V/BXE, to DN 50, stroke 14 mm
0372338002	V/B6 DN 65...150, V/BXD, V/BXE from DN 65, stroke 40 mm
0372338003	Conversion kit from AV*2*4SF132-5 to standard actuator AV*2*4SF132
0372338004	Conversion kit from AV*2*4SF132-6 to standard actuator AV*2*4SF132

Adapter set for non-SAUTER valves

Type	Description
0372376010	Siemens with 20 mm stroke or 10 mm spindle diameter
0372376014	Siemens with 40 mm stroke or 14 mm spindle diameter
0372377001	Johnson Controls DN 15...150, 14, 25, 40 mm stroke, spindle diameter 10, 12, 14 mm
0372378001	Honeywell with 20 mm stroke
0372378002	Honeywell with 38 mm stroke
0372386001	LDM type RY113 R/M
0372389001	ITT-Dräger, DN 15...32
0372389002	ITT-Dräger, DN 40...50
0378263001	End stop (needed for V/BXD, V/BXE DN 15...50, V/B6 DN 15 with kvs ≤ 1 m³/h)
0386263001	Cable gland M16 × 1.5
0386263002	Cable gland M20 × 1.5
0372387001	SAUTER Satchwell VZF1727 mounting set
0372461001	Forced operation for AV*2*4S
0510390052	Adapter set for non-SAUTER valves (Frese), stroke 20 mm
0510390053	Adapter set for non-SAUTER valves (Frese), stroke 40/43 mm

💡 Adapter: Not needed for version AV*2*4SF132-6

💡 Potentiometer 130 Ω: This potentiometer must only be used as a voltage divider.

Description of operation

This valve actuator may only be used for activation of 2- or 3-way valves from SAUTER or with non-SAUTER valves compatible with the adapter set. Other applications are not permitted.

After a restart or a start after triggering the reset (terminal 21), a waiting time of up to 45 s elapses until the actuator is available again. Depending on the type of connection (see connection diagram), the actuator can be used as a continuous (0...10 V or 4...20 mA), 2-point (OPEN/CLOSE) or 3-point actuator (OPEN/STOP/CLOSE).

The running time of the actuator can be set with switches S1 and S2 according to the relevant requirements. Switches S3 and S4 are used to configure the characteristic (equal-percentage, linear or quadratic).

The external crank handle enables manual positional setting. When the crank handle is folded out, the motor is switched off. After the crank handle is folded back, the spring function is active again and the actuator moves to the target position (without initialisation). When the crank handle is folded out, the actuator remains in this position.

Intended use

This product is only allowed to be used in HVAC building systems for control and regulation purposes. Other uses require the prior consent of the manufacturer.

The section "Description of operation" and all product instructions in this data sheet must be observed.

Modifying or converting the product is not permitted.

Improper use

The valve actuator is not suitable for:

- Transport applications and at altitudes above 2000 metres

- Use in areas where there is a risk of condensation
- Use in plants with high pressure surges
- Use as a safety device in pressure systems of categories I to IV as per Pressure Equipment Directive 2014/68/EU or Pressure Equipment (Safety) Regulation 2016.

**Notice in accordance with California Proposition 65**

The product contains lead. To be marketed in North America, the appropriate warnings must be affixed to the product or packaging.

Engineering and fitting notes

Condensate, dripping water, etc. must be prevented from entering the actuator along the valve spindle.

The actuator is mounted directly on the valve and fixed with screws (no further adjustments are required). The actuator is connected with the valve spindle automatically. Depending on the type and how it is delivered ex works, the stroke of the actuator spindle is 0 % or 100 %.

The housing contains three break-out cable inlets which are broken out automatically when the cable inlet is screwed in.

The concept of DC motor/electronics enables parallel operation of multiple valve actuators of the same type. The cross-section of the power cable must be selected based on the cable length and the number of actuators. With five actuators wired in parallel and a cable length of 50 m, we recommend a cable cross-section of 1.5 mm² (power consumption of the actuator × 5).

The maximum equipment for the actuator is one 230 V module, one additional accessory component (auxiliary contact or potentiometer) and the split-range unit.

**Notice**

Extreme pressure surges in the system can lead to gear damage and must be prevented by using anti-surge valves.

Outdoor installation

We recommend protecting the devices from the weather if they are installed outside buildings.

Initialisation and feedback signal

The actuator initialises itself autonomously, whether continuous, 2-point or 3-point. Once a voltage is applied to the actuator for the first time and the waiting time has elapsed, the actuator moves to the lower limit stop of the valve and thus enables automatic connection with the valve spindle. Then it moves to the upper stop and the value is detected and saved via a travel measurement system. The control signal and the feedback are adjusted to this effective stroke. After a power failure or a spring return, no re-initialisation is carried out. The values remain saved.

For a re-initialisation, the actuator must be connected to the power supply and there must be a constant input signal at 3u or 3i. An initialisation is triggered by folding the crank handle out and back twice within 4 s. Then the two LEDs flash red.

During initialisation, the feedback signal is inactive or equal to the value "0". Initialisation is carried out with the shortest running time. The re-initialisation is only valid when the whole process is complete. Folding the crank handle out again interrupts this process.

If the valve actuator detects jamming, it reports this by setting the feedback signal to 0 V after approx. 90 s. During this time, the actuator tries to overcome the jamming. If the jamming can be overcome, the normal control function is activated again, and the feedback signal is restored.

Spring return

If the supply voltage fails or is switched off, or if a monitoring contact at terminal 21 is activated, the brushless DC motor releases the gear unit and the preloaded spring moves the actuator to the relevant end position (depending on the model). In the process, the control function of the actuator is locked for 45 s (both LEDs light up green) so that the end position can definitely be reached. The reset speed is controlled using the motor so that no pressure surges can occur in the supply line. The brushless DC motor has three functions: As a magnet for holding the position. As a brake, by operating as a generator, and as a motor for the control function. After a spring-return function, the actuator does not re-initialise itself.

Connection as 2-point valve actuator (24 V)

This activation (OPEN/CLOSE) can be performed via two wires. The voltage is applied to terminals 1, 2a and 21. When voltage (24 V) is applied to terminal 2b, the actuator spindle moves out. After this voltage is switched off, the actuator moves to the opposite end position. In the end positions (valve limit stop or maximum stroke reached) or in the case of an overload, the electronic motor cut-off is activated (no limit switches).

The running times can be set using the coding switch. The characteristic cannot be selected here (the result is the characteristic of the valve). The feedback signal is active as soon as the initialisation has been performed and there is a voltage on terminal 21. Terminals 3i and 3u must not be connected.

Connection as 3-point valve actuator (24 V)

The valve can be moved to any desired position by applying voltage to terminals 2b (or 2a) and 21. If voltage is applied to terminals 1 and 2b, the actuator spindle moves out. It moves in when the electrical circuit is closed via terminals 1 and 2a.

In the end positions (valve limit stop or maximum stroke reached) or in the case of an overload, the electronic motor cut-off is activated (no limit switches). The direction of the stroke can be changed by swapping the connections.

The running times are set using the coding switch. The characteristic cannot be selected here (the result is the characteristic of the valve). The feedback signal is active as soon as the initialisation has been performed and there is a voltage on terminal 21. Terminals 3i and 3u must not be connected.

Connection with 230 V or 100...110 V as 2-point/3-point or with continuous activation of valve actuator (accessory 0372332)

The accessory module is plugged into the connection area and then connected as required. The running times can be selected using the coding switch on the baseboard. The characteristic can only be selected for continuous activation. The characteristic of the valve is decisive.

A switch is integrated into the module which is automatically moved to the correct position when the module is being installed. In this application, the switch lever is in the top position.

The accessory module is not suitable for 2-point actuation.

Connection to a control voltage (0...10 V or 4...20 mA)

The built-in positioner controls the actuator depending on controller's output signal y .

A voltage signal (0...10 V $-$) at terminal 3u or a current signal at terminal 3i serves as the control signal. If there is a control signal on both terminals (3u (0...10 V) and 3i (4...20 mA)) at the same time, the input with the higher value has priority.

Direction of operation 1 (mains power supply on internal connection 2a):

When the positioning signal is increasing, the actuator spindle extends.

Direction of operation 2 (mains power supply on internal connection 2b):

When the positioning signal is increasing, the actuator spindle retracts.

The starting point and control span are fixed. A split-range unit (only for voltage input 3u) designed for installation in the actuator is available as an accessory for adjusting partial ranges (see split-range unit function).

After the connection of the power supply and the initialisation, the actuator moves to every valve stroke between 0 % and 100 %, depending on the control signal. Thanks to the electronics and the travel measurement system, no stroke is lost, and the actuator does not require periodic re-initialisation. When the end positions are reached, this position is checked, corrected if necessary, and saved again. It is thus possible to operate multiple actuators of the same type in parallel. The feedback signal $y_0 = 0...10$ V corresponds to the effective valve stroke of 0 to 100 %.

If the control signal 0...10 V or 4...20 mA is interrupted with direction of operation 1, the actuator spindle moves in completely, or moves out completely with direction of operation 2.

The coding switch can be used to set the characteristic of the valve: Linear, equal-percentage or quadratic. This characteristic can only be generated when the actuator is used as a continuous actuator. Additional switches can be used to select the running times (with the 2-point, 3-point or continuous functions).

Continuous actuation can also be used with a power supply of 230 V or 110 V (accessory required). You must ensure that the neutral wire of the controller is connected to the control voltage. The neutral wire of the power supply may only be used for the module.

LED indicator: The indicator consists of bi-colour LEDs (red / green).

Both LEDs flash red	Initialisation
Top LED lights up red	Top limit stop or "CLOSED" position reached
Bottom LED lights up red	Bottom limit stop or "OPEN" position reached
Top LED flashes green	Actuator is running, moving to "CLOSED" position
Top LED lights up green	Actuator is stopped, last direction of travel "CLOSED"
Bottom LED flashes green	Actuator is running, moving to "OPEN" position
Bottom LED lights up green	Actuator is stopped, last direction of travel "OPEN"
Both LEDs light up green	Waiting time after switching on or after spring return
No LED lights up	No power supply (terminal 21)
Both LEDs flash red and green	Actuator is in manual mode

Valve design

SAUTER provides various tools for valve design and engineering:

- ValveDim smartphone app
- ValveDim PC program
- ValveDim slide rule

You can find the tools under the link www.sauter-controls.com/en/performance/valve-calculation/ or scan the QR code

**Split-range unit (accessory 0313529)**

This accessory can be built into the actuator or externally housed in an electrical junction box. Starting point U_0 and control span ΔU can be set with the potentiometer. In this way, several control units can be operated in sequence or cascade by the control signal of the controller. The input signal (partial range) is converted into an output signal of 0...10 V.

Additional technical information

The yellow housing, consisting of the front part, rear part and connecting lid, only serves as a cover. The push-buttons for manual adjustment are located on the front side. The DC motor, electronic control unit, load-bearing section and maintenance-free gear unit are located in the housing. The actuator spindle and the column are made of rust-proof material. The inner printed circuit boards, gear unit and spring are made of steel. The valve spindle guide and the valve neck coupling are made of die-cast aluminium.

**Note on the ambient temperatures**

With a media temperature of up to 110 °C in the valve, the ambient temperature is allowed to reach 60 °C. With a media temperature above 110 °C, the ambient temperature must not exceed 55 °C. Otherwise, the intermediate piece accessory 0372336180 must be fitted.

Abbreviations used

Abbreviation	Directive
LV-D	Low-Voltage Directive 2014/35/EU
EESR-2016	Electrical Equipment (Safety) Regulations 2016
EMC-D	Electromagnetic Compatibility Directive 2014/30/EU
EMC-2016	Electromagnetic Compatibility Regulations 2016
RoHS-D	RoHS Directives 2011/65/EU and 2015/863/EU
RoHS-2012	Restriction of Hazardous Substances (RoHS) Regulations 2012

Auxiliary change-over contacts

0372333 Switch rating max. 250 VAC, current min. 250 mA at 12 V (or 20 mA at 20 V)

001 Switch rating max. 12...30 VDC, current max. 100 mA

0372333 Switch rating max. 250 VAC, current min. 1 mA at 5 V

002 Switch rating max. 0.1...30 VDC, current 1...100 mA

If it is used once in the range up to 10 mA or up to 50 V, the gold plating is eliminated. The switch can then only be used for a higher switch rating.

Warning

- Actuators with safety functions must be checked regularly for operability (test run).
- If damage can occur due to the failure of the control unit, additional protective measures must be implemented.
- Due to the high risk of injury, it is forbidden to remove the spring from the device.

Desired character. curve	Switch coding	Characteristic curve for valve	Characteristic curve for drive	Effective on valve
Equal percentage				
Quadratic				
Linear				
Equal percentage				
Linear				

= factory setting

Run time per mm	Switch coding	Run time for 14 mm stroke	Run time for 20 mm stroke	Run time for 40 mm stroke
2s		28s ± 1	40s ± 1	80s ± 4
4s		56s ± 2	80s ± 4	160s ± 4
6s		84s ± 4	120s ± 4	240s ± 8
= factory setting				

Disposal

When disposing of the product, observe the currently applicable local laws. More information on materials can be found in the Declaration on materials and the environment for this product.

Connection diagram

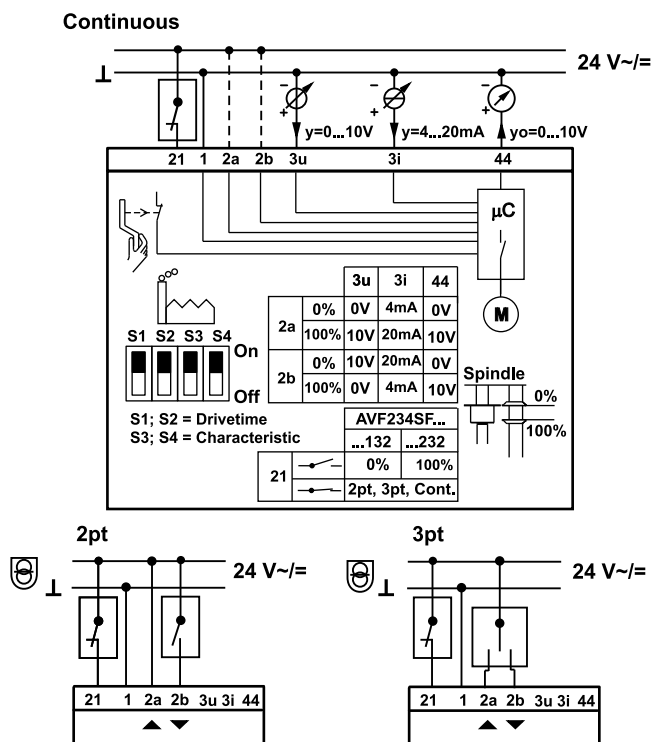

Accessories

0372332001

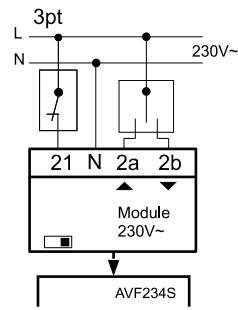
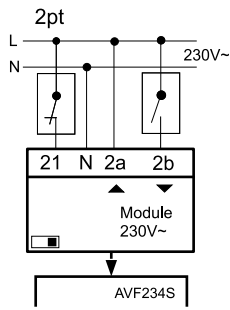
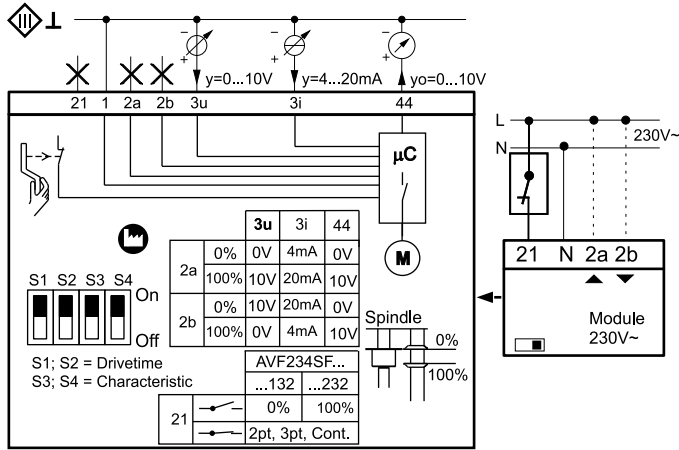

A10653c

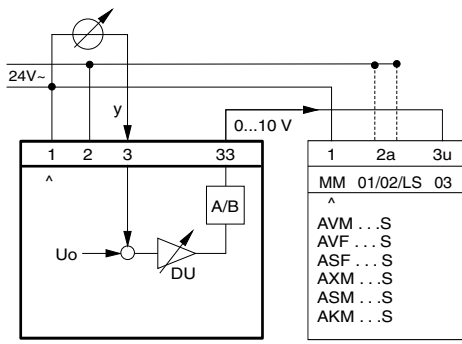

372333

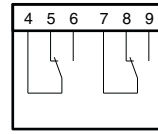

372334

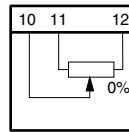

Dimension drawing

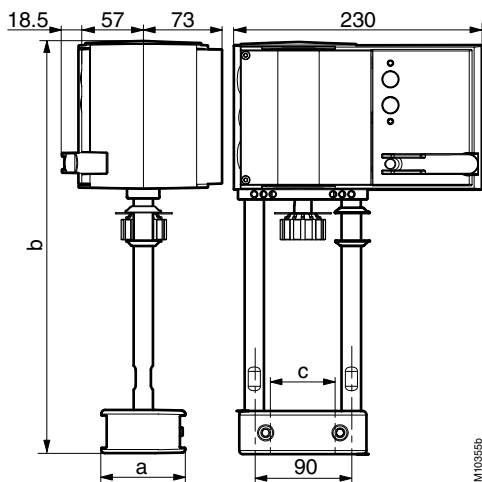

M10655b

Type	a	b	c
AVF234SF132/232	64	289	44
AVF234SF132-5	58	289	38
AVF234SF132-6	78	382	60

Accessories

0372336 180
0372336 240

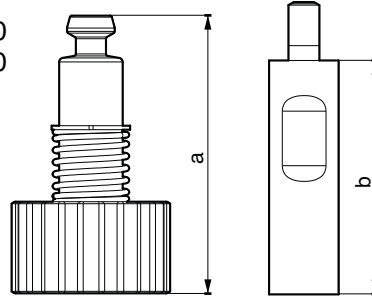

0372336	T (°C)	a (mm)	b (mm)
180	180	69,4	60
240	240	109,4	100